

Numberers

An ideal tool to produce random numbering or batch marking on most metals and many plastics

- Designed to suit a variety of stock shanks giving the option of use by hand and hammer or Percussion Press. Larger sizes with a 'one piece frame' suitable for heavy duty hand and hammer marking applications
- The units contain six wheels, each wheel has sharp faced positive impression characters engraved 0-9(inclusive) and a blank station on each wheel allows for a non marking position.
- The wheels can be rotated to any given position and then locked in place by the securing pin - offering a quick and simple inscription change without the use of tools

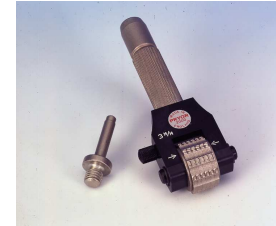

1.0mm - 3.0mm character size suitable for use by hand & hammer or machine

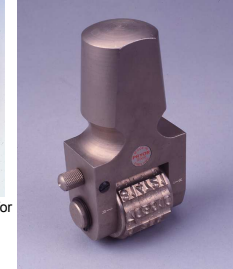

4.0mm - 6.0mm character size 'one piece' frame for hand & hammer use

Available from stock					
CHARACTER SIZE		Suitable for use by		Length of marked impression	
Metric	Imperial	Hand	Machine	mm	inch
1.50mm	1/16"	•	•	8.40mm	0.34
2.00mm	5/64"	•	•	11.20mm	0.45
2.50mm	3/32"	•	•	14.00mm	0.56
3.00mm	1/8"	•	•	16.80mm	0.67
4.00mm	5/32"	•		22.40mm	0.9
5.00mm	3/16"	•		28.00mm	1.12
6.00mm	1/4"	•		33.60mm	1.34

always take the character size measurement from the "crown" of the character

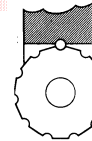

The security pin not only fastens the wheels in position, but also transmits the compressive load in the body of the tool, directly to the point of impact.

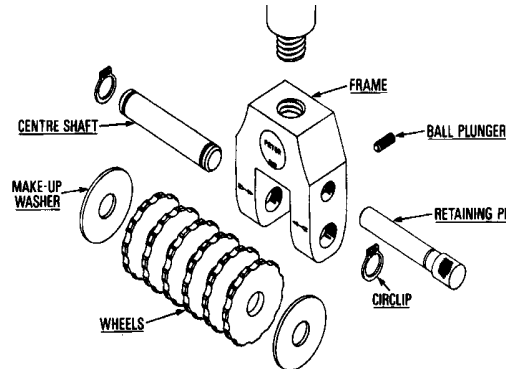

SHANKS

Ref	Size	Suit Pryor Machine
HMS0630	1/4" dia x 1.3/16"	114M
HMS0830	5/16" dia x 1.3/16"	
HMS1040	3/8" dia x 1.57"	115M
HMS1650	5/8" dia x 2"	116M
HMS2025	25/32" dia x 1"	
HMS2040	25/32" dia x 1.57"	
HMS25.4-40	1" dia x 1.1/2"	
HMS2090	20mm knurled for manual use	

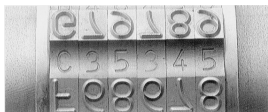

Tell-Tale characters in the wheel grooves show the actual characters in the marking position - particularly helpful when being used in a machine

PRYOR
MARKING TECHNOLOGY

PRYOR NUMBERERS are manufactured to quality system ISO 9001:2000

Edward Pryor & Son Ltd. Egerton Street Sheffield England
Tel: (+44) 114 276 6044 Fax : (+44) 114 276 6890
email : enquiries@pryormarking.com website : www.pryormarking.com